

Dunedin June Dance 2018

1 MISS ALLIE ANDERSON J32 · 3/4L

Mina Corson: *The Leaflet Dances with Music* · Crib: *MiniCribs* · Diagram: *Keith Rose's Diagrams*

- 1-8** 1s+2s+3s all clap, 1L+2L+3L dance RSh round partners & 3s followed by 2s+1s lead down
- 9-16** All 1/2 turn (Lady under Man's R arm) & 1s followed by 2s+3s lead back to top, 1s+2s+3s set & 1/2 turn partner RH ending in centre of dance
- 17-24** 1s+2s+3s dance Promenade
- 25-32** 1s+2L dance RH across, 1M ending in 2nd place (2M step up 27-28) 1s+2M dance LH across (2L step up 31-32) 1s end in 2nd place own side

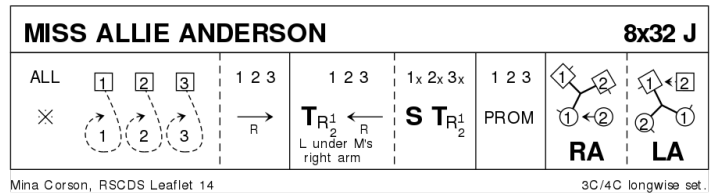

2 THE CLANSMAN R32 · 2/4L

Derek Haynes: *RSCDS XXXII 8* · Crib: *MiniCribs* · Diagram: *Keith Rose's Diagrams*

- 1-8** 1s cross RH & cast down 1 place, 2s+1s dance 1/2 RH across & set
- 9-16** 1s+2s dance R&L, ending with Men turning Ladies into centre to form a line across
- 17-24** 1s+2s dance the Targe :
- 17-18** 1st & 2nd Ladies 3/4 turn RH **while** Men dance 1/4 way round anticlockwise
- 19-20** 1st Man with 2nd Lady & 1st Lady with 2nd Man full turn LH
- 21-22** 1st & 2nd Ladies 3/4 turn RH **while** Men dance 1/4 way round anticlockwise
- 23-24** 1st Man with 2nd Lady & 1st Lady with 2nd Man turn LH to end on sides 1s facing up & 2s facing down
- 25-32** 2s+1s set facing on sides, turn to face partners & set, 1s lead up crossing RH & cast to 2nd place on own sides

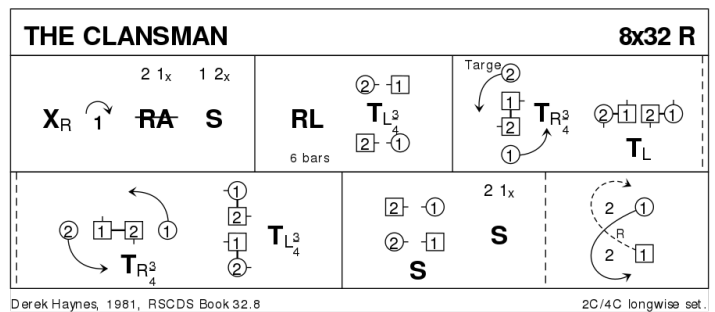

3 COLLINGWOOD OAKS S32 · 3/4L

Jen Wood: *Dunedin Dances Book 6* · Crib: *MiniCribs*

- 1-8** 1s turn RH, cast (2s step up). 1s Petronella turn into lines of 3 across (1L between 2s, 1M between 3s). All set
- 9-16** 1L+2M+3M also 1M+2L+3L dance RH across. 1s turn LH to 2nd place own sides & all set
- 17-24** 1s followed by 2s dance down, cast up round 3s, dance up to top & 1s cast to face 1st corners **while** 2s end in 1st place
- 25-32** 1s dance Corner Pass+Turn with 1st corners, dance Corner Pass+Turn with 2nd corners. 1s pass RSh to 2nd place own sides

4 RYE TWIST R32 · 5/5L

Sue McKinnell: RSCDS XLVIII 5 · Crib: MiniCribbs · Diagram: Keith Rose's Diagrams

- 1-4** 1M+2s dance 1/2 reel of 3 across (1M+2L pass LSh). 1M finishes between 2s facing down
- 5-8** 1M+3s dance 1/2 reel of 3 across (1M+3M pass RSh), 1M finishes between 3s facing down **while** 1L+2s dance 1/2 reel of 3 across (1L+2L pass RSh). 2L finishes between 2s facing down. 2s finish in 1st place
- 9-12** 1M+4s, 1L+3s repeat bars 5-8 (1M+4L, 1L+3M pass LSh). 3s finish in 2nd place
- 13-16** 1M+5s, 1L+4s repeat bars 5-8 (1M+5M, 1L+4L pass RSh). 4s finish in 3rd place
- 17-20** 1M dances out of end, casts round 5L place, crossing to 4M place **while** 1L+5s dance 1/2 reel of 3 across (1L+5M pass LSh). 1L finishes in 4L place, 5s in 5th place
- 21-24** 1s+5s dance 1/2 LH across, cross LH with partner
- 25-32** All couples set, cross RH with partners, all set, cross RH with partners 2 3 4 5 1

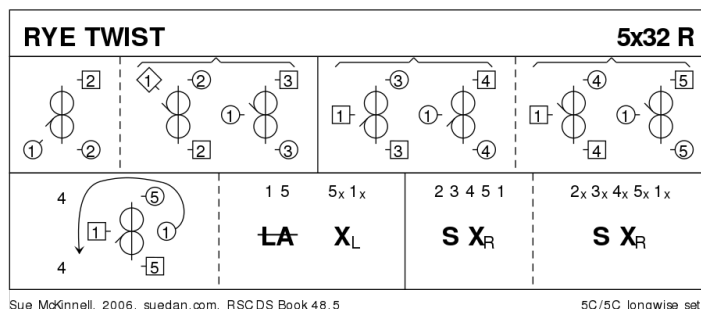

5 THE WEE COOPER O' FIFE J40 · 2/4L

Hugh Foss: Dances To Song Tunes · Crib: MiniCribbs · Diagram: Keith Rose's Diagrams

- 1-10** 1s set & cross RH, set & cross down LH & cast up round 2s to original place - 1 2
- 11-20** 1s+2s dance R&L 1.1/4 times (ie 5 moves) - (1) (2)
- 21-30** 1s+2s set & dance 1/2 RH across, set & dance 1/2 LH across, 1L+2M continue turning 1/2 LH in centre as 1M & 2L cast, 1M down & 1L up to form line across all facing partners ready for ...
- 31-40** 1s+2s dance full reel of 4 across. Pass partners RSh & dance back to own side (2s to top, 1s into 2nd place)

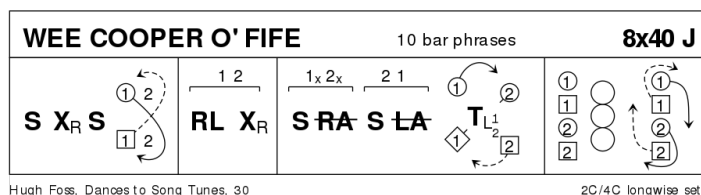

6 JOHN MCALPIN S32 · 3/4L

Hugh Foss: Magazine Dances 2005-2009 · Crib: MiniCribbs · Diagram: Keith Rose's Diagrams

- 1-8** 1s Adv+Ret 1 step (touch RH) & cross LH, lead down RH 1 place & 3/4 turn LH to face 1st corners
- 9-16** 1s turn RH 1st corner & turn partner LH, turn RH 2nd corner then cross LH to 2nd place own sides
- 17-24** 2L+1L+3L set, Adv+Ret & set **while** 2M+1M+3M stand for 2 bars, set, Adv+Ret
- 25-32** 2s+1s+3s cross RH, circle 6H round to left 1/2 way, cross LH & circle 6H round to right 1/2 way

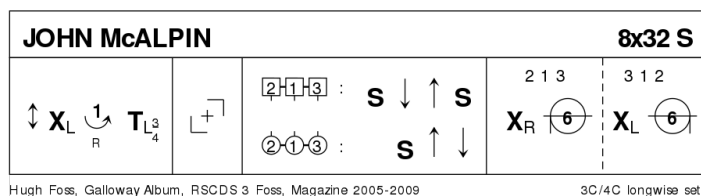

7 THE BEES OF MAGGIEKNOCKATER J32 · 4/4L

John Drewry: *The Canadian Book of Scottish Country Dances* · Crib: *MiniCrib*s · Diagram: *Keith Rose's Diagrams*

- 1-8** 1s cross RH & cast 1 place, dance RH across with 3s & end 1M+3L also 1L+3M in prom hold facing out to pass corner person RSh
- 9-24** All dance 4x1/2 Reels of 3 on sides (to right to start, then left, right & left) with 1s+3s changing partners in centre at end of each 1/2 Reel to progress Men clockwise & Ladies anticlockwise. End in centre 1s facing down & 3s facing up
- 25-32** 1s dance between 3s turning 3s with nearer hand 1.1/2 times, crossing over to own sides & turn 4th person 1.1/2 times (Men RH & Ladies LH)

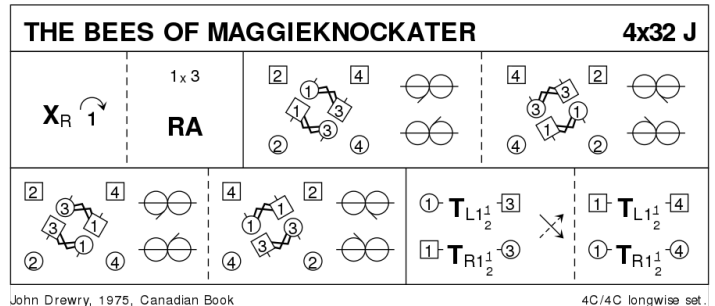

8 THE COLLEGE HORNPIPE R32 · 3/4L

W Boag (18C): *RSCDS XX 12* · Crib: *MiniCrib*s · Diagram: *Keith Rose's Diagrams*

- 1-8** 1s+2s+3s circle 6H round & back
- 9-16** 1s+2s+3s Promenade
- 17-24** 1s cross RH, cast to 2nd place, cross LH, cast to 3rd place & lead up to face 1st corners
- 25-32** 1s dance 'Hello-Goodbye' setting ending with a clap & petronella turn to 2nd places

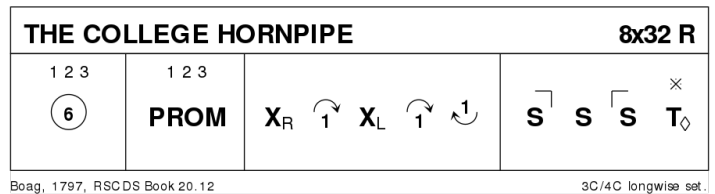

9 BONNIE ANNE J96 · 4/4L

Scottish Dances collected by Mary Isdal MacNab · Crib: MiniCribbs · Diagram: Keith Rose's Diagrams

- 1-16** All dance petronella round back to places
- 17-32** 1L sets adv to 1M & turns 2H, repeat with 2M, 3M & 4M, as 2L, 3L & 4L dance up 1 pl & repeat at 2 bar intervals until Ladies are on Men's side
- 33-40** 1L followed by 2L, 3L & 4L weave 'out & in' on Men's side till 1L+2L are between 1M+2M & 3L+4L between 3M+4M, all dance across to place
- 41-48** All set twice to partners & turn RH into Allemande hold in centre
- 49-64** Each couple in turn sets advancing/turning to form a square set, 1s to 1st place facing down, 2s to 4th place, 3s to 2nd place & 4s to 3rd place
- 65-72** Ladies continue setting **while** Men set dancing in & turning to face partner & 1M & 4M set twice facing partner as 2M & 3M set once & dance clockwise to face 1M/4M forming a line in centre for reel of 4. 2 1 4 3
- 73-80** Ladies set **while** Men dance reel of 4 & end facing partners
- 81-88** All set twice & turn 2H into longwise pstns
- 89-96** 1s+2s also 3s+4s dance All Round Poussette (Popular variation - progressive Poussette & repeat dance from new positions)

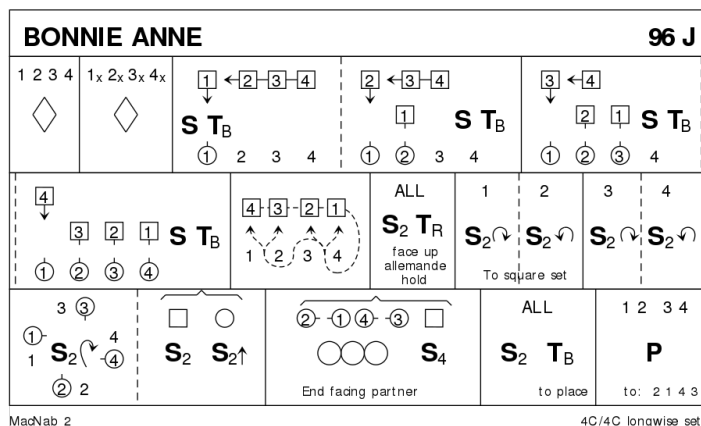

10 THE HIGHLAND RAMBLER R40 · 3/4L

Roy Goldring: Silver Jubilee 25 - Leeds Branch · Crib: MiniCribbs · Diagram: Keith Rose's Diagrams

- 1-8** 1s dance in & cast to 2nd place, dance RH across with 3s
- 9-16** 2s+1s dance LH across, 1L followed by partner cast up round 2L & dance down middle to 1L between 3s & 1M between 2s
- 17-24** 1s+2s+3s dance down the middle & back
- 25-32** 1M followed by partner cast down round 2L to 2nd places on own side & turn RH
- 33-40** 2s+1s+3s circle 6H round & back

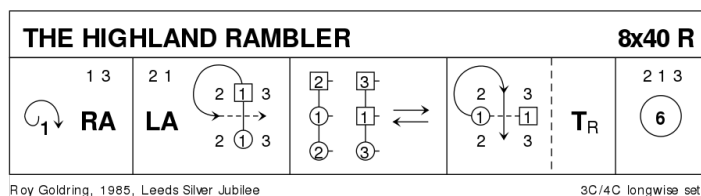

11 FAIR ENOUGH J32 · 4/4L

Liza Halpenny: RSCDS LI 4 · Crib: MiniCribbs · Diagram: Keith Rose's Diagrams

- 1-8** All 4 couples DoSiDo. All turn partners RH, 2s+3s end in middle facing up in allemande hold, 1s+4s end on sides
- 9-16** 2s+3s dance allemande
- 17-24** 1s+4s cross RH, cast down/up (3s & 2s step up/down) & 1s+4s dance 1/2 Figs 8 round end couples (1s round 3s, 4s round 2s)
- 25-32** All circle 8H round & back

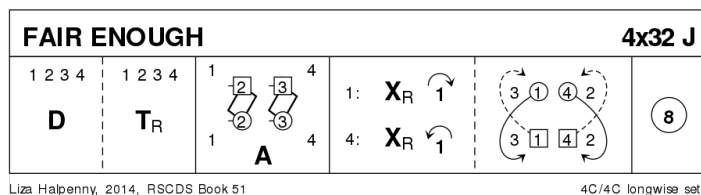

12 THE DUNDEE WHALER S32 · 4/4L

Roy Clowes: Ormskirk Scottish Dances - Memorial Edition · Crib: MiniCribS · Diagram: Keith Rose's Diagrams

- 1-8** 2s & 4s dance Petronella to opposite sides
- 9-16** 1s+2s & 3s+4s dance Ladies Chain
- 17-24** 1s & 3s dance Petronella to opposite sides
- 25-32** 1L+2M change places LH, 1M+2L also
1L+3L change places RH, 1M+3M also 1L+4M change places LH & 1M+4L change RH

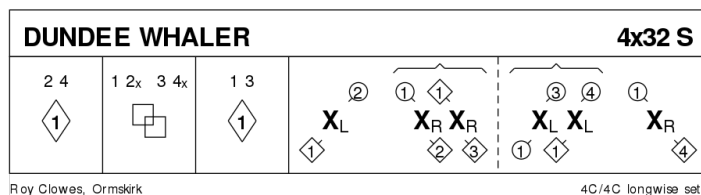

13 THE PINES OF PITLOCHRY J48 · 3/4L

Sam Firth: Scottish Dance Archives · Crib: MiniCribS · Diagram: Keith Rose's Diagrams

- 1-8** 1s cross RH & cast 1 place, 1L dances 1/2 Fig of 8 round 2s & 1M round 3s end in centre each facing 1st corner & holding LH
- 9-16** 1s set to 1st corners, turn inwards & set to 3rd corner, 1/4 turn RH & set to 2nd corners, turn inwards & set to 4th corner
- 17-24** 1L with 2s & 1M with 3s dance RH across, 1s turn 1.1/2 times LH in centre **while** 2s & 3s chase round clockwise 1/2 way
- 25-32** 1L with 2s & 1M with 3s dance RH across (same couple but at other end), 1s turn 1.1/2 LH **while** 2s & 3s chase round clockwise 1/2 way
- 33-40** 1L with 2s & 1M with 3s dance full LSh reels of 3, 1s ending on own sides in 2nd place
- 41-48** 2s+1s+3s circle 6H round & back

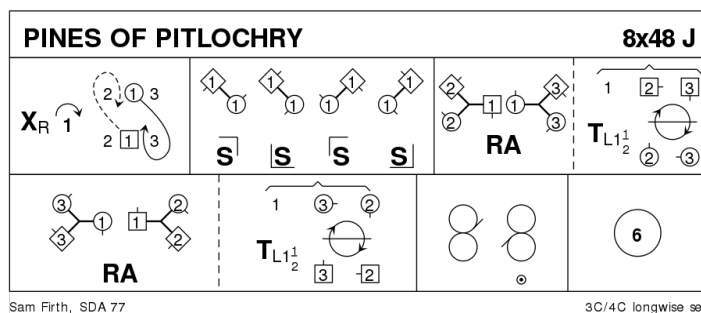

14 JOHNNIE WALKER M128 · 4S

Norman & Helen Robson: The Whisky Collection · Crib: MiniCribS · Diagram: Keith Rose's Diagrams

- 1-8** All circle 8H round & back
- 9-16** All set to corners & turn RH, set to partners & turn LH
- 17-24** 1s & 3s advance to centre & lead out through sides with opposite partner, cross & dance to opposite sides & turn partner RH 1.1/2 times
- 25-32** 2s & 4s repeat 17-24
- 33-40** All Ladies petronella one place to right & all set, Ladies petronella on to next place to right & set
- 41-48** All Men petronella one place to right & all set, Men petronella on to next place to right & set
- 49-64** All dance Grand Chain once round & dance Allemande anticlockwise
- 65-128** Repeat in Jig time

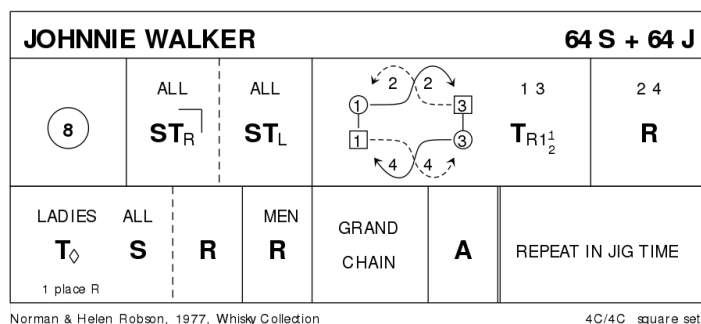

18 THE REEL OF THE ROYAL SCOTS

R32 · 3/4L

Roy Goldring: *The Leaflet Dances with Music · Crib: MiniCrib*s · Diagram: Keith Rose's Diagrams

- 1-8** 1s 1/2 turn 2s on sides (1M RH - 1L LH) to face out, 2s+1s+3s set, 1s 1/2 turn 3s on sides (1M LH - 1L RH) end 3s facing out & 2s+3s+1s set
- 9-16** 1s followed by 3s dance up between 2s, cast down 1 place, dance in & 1s cast up to 2nd place 3s end in 3rd place
- 17-24** 1s turn 1st corners RH, pass partner RSh turn 2nd corners RH & cross passing partner RSh to 2nd place own sides
- 25-32** 2s+1s+3s circle 6H round & back

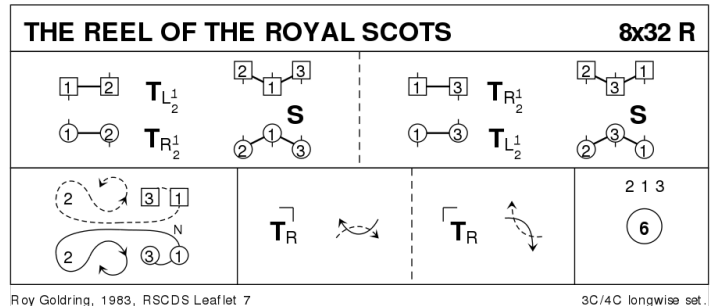

19 MAJOR IAN STEWART

J32 · 3/4L

John Drewry: *RSCDS XXXV 4 · Crib: MiniCrib*s · Diagram: Keith Rose's Diagrams

- 1-8** 1s+2s 1/2 turn partners RH & dance RH across 1/2 way, 2s+1s full turn partner RH ending with 2s at top & 1s in 2nd place
- 9-16** 2s+1s+3s dance reels of 3 on own sides (1L dances in & up as 1M dances in & down to start) & 1s end facing 1st corners
- 17-24** 1s set to 1st corners then to each other across the dance, set to 2nd corners & Petronella turn to 2nd place own sides
- 25-32** 2s+1s+3s circle 6H round to the left for 6 steps, pivot & chase back to places

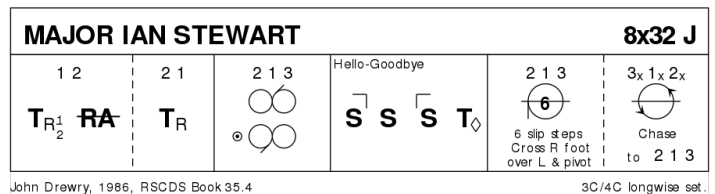

20 J. B. MILNE

R32 · 3/4L

Hugh Foss: *Angus Fitchet Scottish Dance Album · Crib: MiniCrib*s · Diagram: Keith Rose's Diagrams

- 1-8** 1M+2L set advancing & turn RH, 1L+2M set advancing & turn RH
- 9-16** 1s set to each other & turn 2H, cast to 2nd place & Petronella turn to Lady between 2s & Man between 3s
- 17-24** 1s set & 3/4 turn RH **while** 2s+3s change places RH on sides & set, 1s repeat but 2s & 3s cross RH & set
- 25-32** 1s set & change places RH **while** 2s+3s change places RH on sides & set, 1s cast round corner to 2nd pl own sides as 2s+3s cross RH & all set

