

Dunedin Spring Dance 2019

1 THE LUCKENBOOTH BROOCH J32 · 3/4L

John Bowie Dickson: *Reels and Wheels* (CD booklet) · Crib: *MiniCribs* · Diagram: *Keith Rose's Diagrams*

- 1-8 1s in prom hold (Lady on Man's left) dance reel of 3 with 2s (RSh to 2M) & end facing 3M
- 9-16 1s dance reel with 3s (RSh to 3M) ending with 1s dancing across to Men's side
- 17-24 1M casts up & 1L dn into centre & dance out Ladies side, 1M cast up & 1L dn to end 1M b'tw'n 2s facing dn & 1L+3s face up as 2s+3s dance R&L
- 25-32 2s+1s+3s set twice, 1s turn RH 1.3/4 times to 2nd places

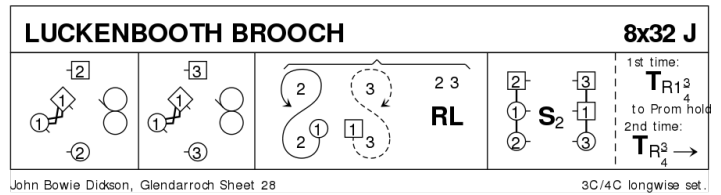

2 FISHERMAN'S REEL R32 · 5S

Petyt, Sue / Gamon, Jane: *Dunblane Holiday* · Crib: *MiniCribs* · Diagram: *Keith Rose's Diagrams*

5 couple square set, 5s in centre facing, 5M back to 4s, 5L back to 2s

- 1-8 1s+2s+3s+4s circle 8H round & back **while** 5s turn RH once & LH 1.1/2 times to end 5M facing 2s & 5L facing 4s
- 9-16 5M+2s also 5L+4s dance RH across, 5s pass LSh & dance LH across with next couple anticlockwise (M with 1s & L with 3s)
- 17-24 5M dances reel of 3 with 1s+2s (in prom hold) giving RSh to 2s **while** 5L reels with 3s+4s giving RSh to 4s
- 25-32 All take ptnrs in prom hold, 5s change pl with 1s RSh, 1s pass 4s RSh, 4s pass 3s RSh, 3s pass 2s RSh & 2s end in centre facing each other

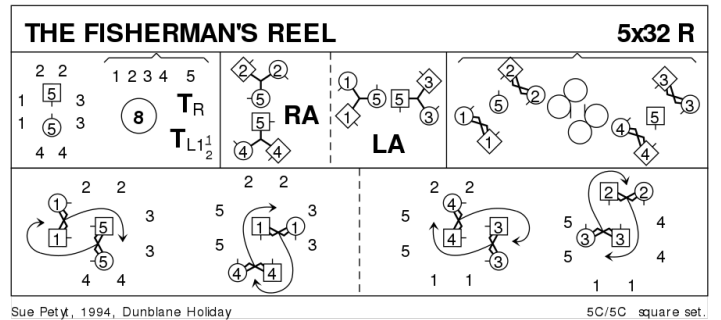

3 AMHUINNSUIDHE CASTLE S32 · 3/4L

Deirdre MacCuish Bark: Coast to Coast with Scotch Mist · Crib: MiniCribs · Diagram: Keith Rose's Diagrams

- 1-8 1s+2s set, 1s cast as 2s, NHJ, dance up & cast into 1st place. 1s turn 1.1/2 LH to face 1st corners
- 9-10 1s+1st corners set
- 11-14 1s pull back RSh to dance 1/2 round each other, 1M passes 2M RSh, 1L passes 3L RSh into middle at top/bottom **while** 2M+3L dance in, turn RH & dance out to places
- 15-16 1s turn RH to face 2nd corners
- 17-24 1s+2nd corners repeat 9-14. Bars 23-24 1s cross RH into 2nd place opp sides facing out
- 25-32 1s dance RSh reels of 3 on opp sides (1s RSh to 1st corners). Bars 31-32 1L crosses up, 1M crosses down into 2nd place own sides as 2s+3s finish reels

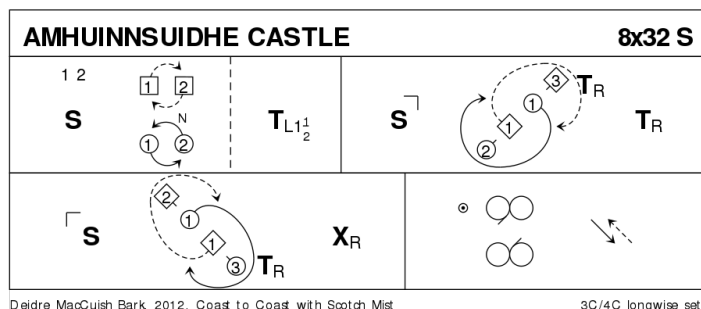

4 MACPHERSON'S JIG J32 · 3T

Roger Bestwick: Rannoch Sheets · Crib: MiniCribs · Diagram: Keith Rose's Diagrams

- 1-8 1s cross out through sides cast down & dance up centre, 1L dances RH across with 2s & 1M dances LH with 3s & all end prom hold
- 9-16 All dance full reel of 3 across set (1s pass 2s RSh to start)
- 17-24 1s dance out through side couples (1M through 3s, 1L through 2s) & cast back to places, all turn partners LH (1s turn 1.1/2 times)
- 25-32 1s+3s dance 1/2 R&L, 3s+2s dance 1/2 R&L all ending 1 place round anticlockwise with 2s at top

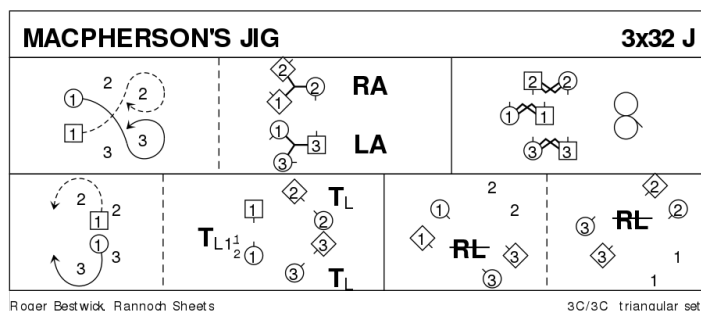

5 STAIRCASE IN STYRIA R40 · 5/5L

Margaret Gray: CD booklet of The Sunday Class Dance Book 2 · Crib: MiniCribs · Diagram: Keith Rose's Diagrams

- 1-8 1s+2M also 3s+4M dance RH across, 1s+2L also 3s+4L dance LH across
 - 9-16 1s+4M also 3s+5M dance RH across, 1s+4L also 3s+5L dance LH across & 1L also 3L end facing out Ladies side with partners behind them
 - 17-24 1s & 3s dance out Ladies' side & cast up 1 place, cross to Mens side & cast up to original place Ladies looping round by the right
 - 25-32 1s cross & cast 1 place, 1s followed by 3s dance up & cast (1s to 3rd place, 3s to 2nd place)
 - 33-40 1s cross & cast 1 place, 1s followed by 5s dance up & cast (1s to 5th place, 5s to 4th place). 2 3 4 5 1
- NB - No stepping up or down until bar 27

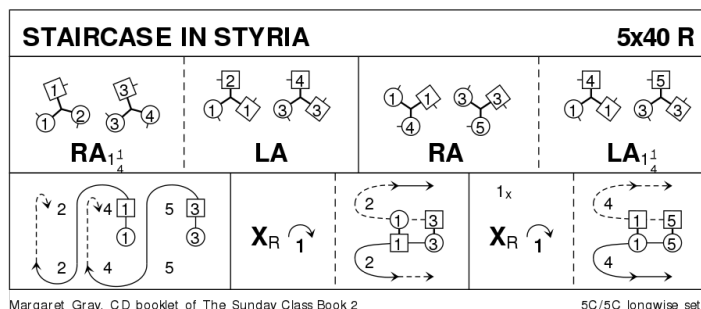

6 CULLA BAY S32 · 4S

Ann Dix: RSCDS XLI 2 · Crib: MiniCribs · Diagram: Keith Rose's Diagrams

- 1-4** 1s & 3s advance & 1/2 turn opposite partner RH & cast out to opposite side
- 5-8** 1s & 3s chase 1/4 round set cl'wise & dance in passing 2s/4s RSh curving in to face 2s/4s as 2s & 4s repeat bars 1-4 & turn right about to face 1s/3s
- 9-16** All dance parallel reels of 4 across set
- 17-24** 2s+1s also 4s+3s circle 4H once round to left, set & dance RH across 1/2 way
- 25-32** 2s+4s dance LH across once round, 2s & 4s dance out through sides passing opp partner RSh & chase round set cl'wise to next place

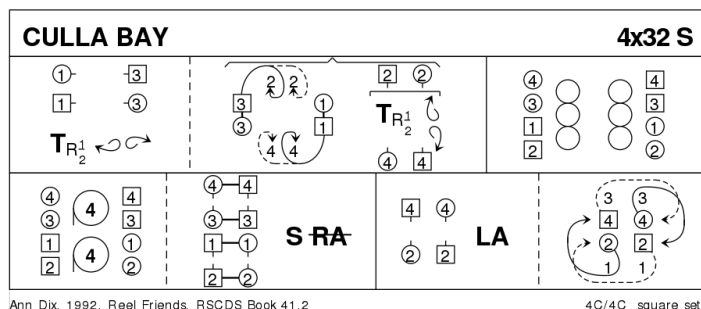

7 THE KELLOHOLM JIG J32 · 3/4L

Peter Hyssett: The Leaflet Dances with Music · Crib: MiniCribs · Diagram: Keith Rose's Diagrams

- 1-8** 1s set & cast 1 place, set on side lines to 1st corners & change places with them RH
- 9-16** 1L+3L also 2M+1M set to each other on sides & change places LH, 1s turn RH 1.1/2 times to 2nd place on own sides
- 17-24** 1s set on side lines to 2nd corners & change places with them RH, 1M+3M also 2L+1L set to each other on sides & change places LH
- 25-32** 3s+1s+2s Adv+Ret, circle 6H round 1/2 way to left

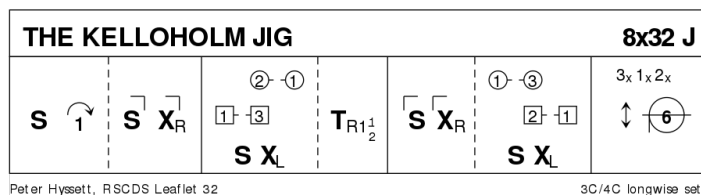

8 THE BELLE OF BON ACCORD S32 · 4/4L

John Drewry: Deeside Book Part 2 · Crib: MiniCribs · Diagram: Keith Rose's Diagrams

- 1-8** 1L & 3L cross down 1 pl & cast up on opp side into centre as 1M & 3M dance across & cast down into centre, 1s+2s & 3s+4s dance RH across
- 9-16** 1s & 3s dance reel of 4 up & down centre of dance
- 17-24** 1s & 3s 3/4 turn RH to face up **while** 2s & 4s dance up on sides & turn in to face down & all set, all circle 4H round to left & end on sides
- 25-32** 1s & 3s lead up between 2s/4s crossing over & cast down 1 place, 1s & 3s turn 2H & 1s dance down to 4th place as 3s cast up on own sides to 2nd pl

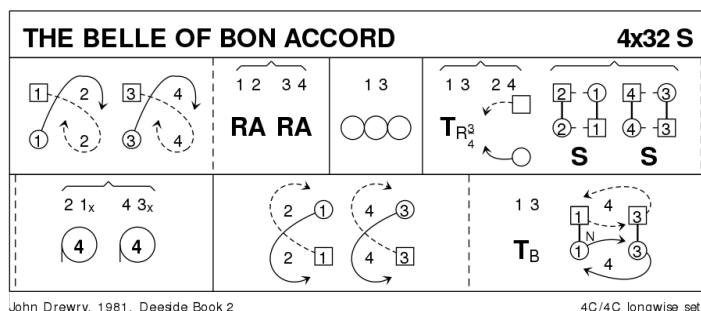

9 THE PLANTATION REEL R32 · 5/5L

Tony Moretti: Pinewoods Collection Vol 2 · Crib: MiniCribbs · Diagram: Keith Rose's Diagrams

- 1-8** 1s & 3s cross RH & cast down 1 place, lead down between the couple below & cast back to 2nd/4th place (opposite sides)
- 9-16** 2s+1s & 4s+3s dance 1/2 R&L & Petronella turn 2 places anticlockwise round square (end in same places as at bar 8)
- 17-24** All dance RH across (1M with 2s, 1L+3M with 4s, 3L with 5s) & 1s & 3s change places with partners to dance LH across
- 25-32** 1s & 3s cross RH cast down 1 place & all turn RH

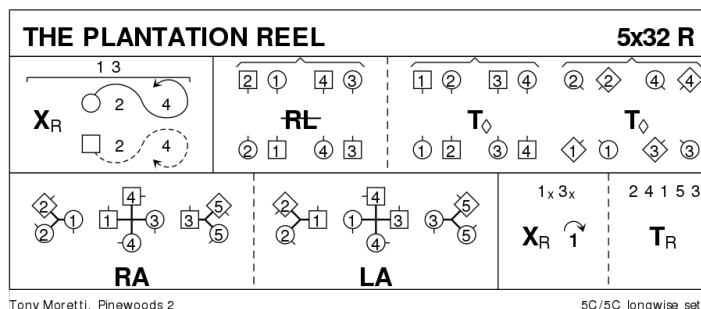

10 THE REEL OF THE ROYAL SCOTS R32 · 3/4L

Roy Goldring: The Leaflet Dances with Music · Crib: MiniCribbs · Diagram: Keith Rose's Diagrams

- 1-8** 1s 1/2 turn 2s on sides (1M RH - 1L LH) to face out, 2s+1s+3s set, 1s 1/2 turn 3s on sides (1M LH - 1L RH) end 3s facing out & 2s+3s+1s set
- 9-16** 1s followed by 3s dance up between 2s, cast down 1 place, dance in & 1s cast up to 2nd place 3s end in 3rd place
- 17-24** 1s turn 1st corners RH, pass partner RSh turn 2nd corners RH & cross passing partner RSh to 2nd place own sides
- 25-32** 2s+1s+3s circle 6H round & back

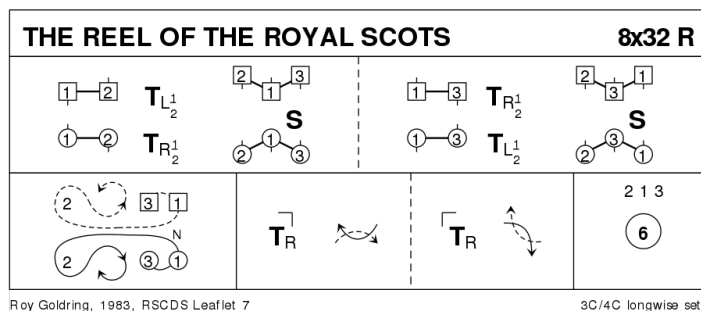

11 THE ELEPHANT'S STAMPEDE J48 · 4S

Lorna Macdonald & Gillian Mackintosh: Aurora 10th Anniversary Book of SCD · Crib: MiniCribbs · Diagram: Keith Rose's Diagrams

- 1-8** All circle 8H round & back
- 9-16** 1s+3s advance & with free hand join with 2s & 4s & retire into longwise set across the dance, all dance 1/2 parallel reels of 4 across
- 17-24** All dance 1/2 R&L at each end of set, turn (person on Mans left) RH 1.1/2 times to form Sq.Set
- 25-32** All Ladies petronella turn to next Ladies place to right & set, repeat to meet partner (all have progressed 1 place to right)
- 33-48** All dance full Schiehallion Reel

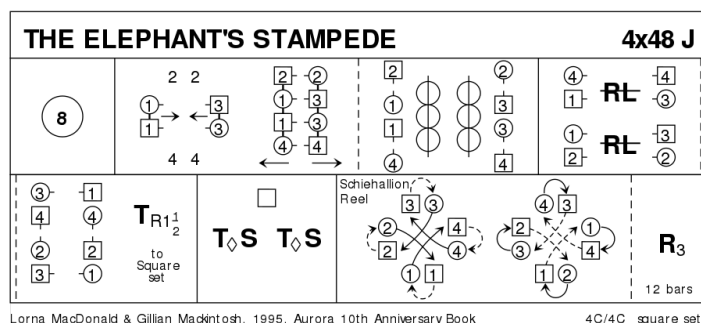

12 THE ROSE OF THE NORTH S32 · 3/4L

Roy Goldring: Silver Jubilee 25 - Leeds Branch · Crib: MiniCribs · Diagram: Keith Rose's Diagrams

- 1-4** 1s lead down below 3s, cross & cast up to 2nd place on opposite side
- 5-16** 2s+1s+3s dance 3 couple R&L, 1s end facing 1st corners
- 17-24** 1s set & turn 1st corner 2H, set & turn 2nd corner 2H. 1s finish BtoB in centre, 1M facing up, 1L facing down
- 25-32** 1s circle 3H round to left (Man with 2s & Lady with 3s), 1s pull back RSh to face each other & set, 1s Petronella turn to 2nd place own side

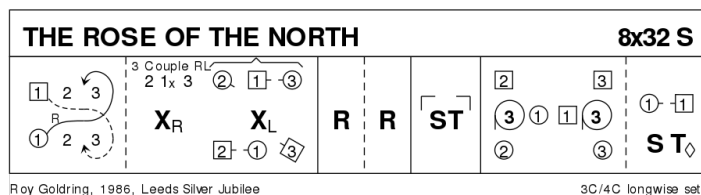

13 PELORUS JACK J32 · 3/4L

Barry Skelton: RSCDS XLI 1 · Crib: MiniCribs · Diagram: Keith Rose's Diagrams

- 1-8** 1s cross RH & cast 1 place, dance RH across with 3s. 1s end with Man facing his 1st corner with his partner behind him
- 9-16** 1s dance Alternating Tandem 1/2 reel of 3 with 1st corners to face Man's 2nd corner, 1s dance Alternating Tandem 1/2 reel of 3 with 2nd corners
- 17-24** 1s dance Alternating Tandem 1/2 reels of 3 with Ladies' 1st corner (pstin), 1s dance Alternating Tandem 1/2 reel with Ladies' 2nd corner (pstin)
- 25-32** 1M followed by partner dance into LH across with 2s, 1s retain LH & 1/2 turn to own sides & 2s+1s+3s set

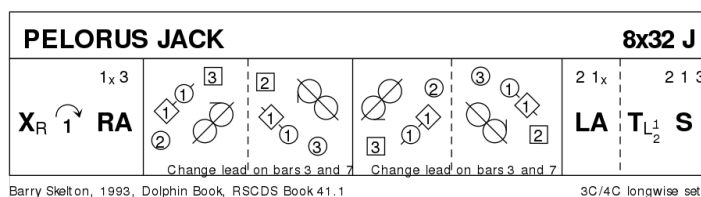

14 SAINT COLUMBA'S STRATHSPEY S32 · 5/5L

Vicky Sproule & Sadie L. Gillan: Saint Columba's Strathspey (Leaflet) · Crib: MiniCribs · Diagram: Keith Rose's Diagrams

- 1-8** 2s+4s dance RH across, 2s dance up **while** 4s dance down, 2s & 4s casting round ends on own sides to face 1st corners
- 9-16** 2s+4s Pass+Turn with 1st corners, pass partner LSh & Pass+Turn with 2nd corners & into centre facing partner (L facing down M up)
- 17-24** 2s+4s dance reel of 4 ending in original places on sides
- 25-32** 2s & 4s set & cast down 1 place **while** 3s & 5s set & dance up 1 place, 1s & 2s turn RH & cast down 1 place. 3 1 5 2 4

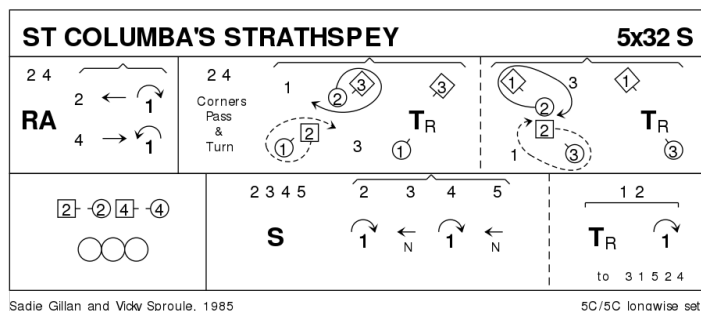

15 BRATACH BANA R32 · 3/4L

John Drewry: Bon Accord Book of Scottish Country Dances · Crib: MiniCribbs · Diagram: Keith Rose's Diagrams

- 1-8 1s turn RH & cast 1 place, 1s dance LSh round 1st corners to 2nd place opposite side facing 2nd corners
- 9-16 1s dance 1/2 Reel of 3 on the sides & dance 1/2 Reel of 3 across (1M with 3s at top, 1L with the 2s)
- 17-24 1s turn LH, turn 3rd crnr RH (1st crnr person) & pass RSh to turn 4th crnr RH ending in 2nd pl own side in prom hold with 4th crnr
- 25-32 1s+4th crnr Prom diag across (pass RSh) to diag opp crnr & 1/2 turn to end 1s in 2nd pl opp side, 1s dance 1/2 Diag R&L (M up, L dn) to end in 2nd pl

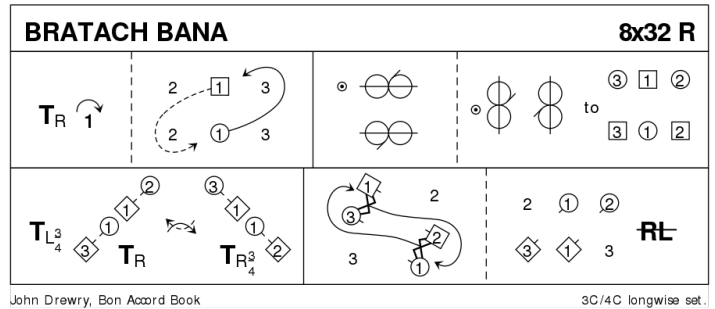

16 THE DREAM CATCHER S96 · 4S

Eileen Orr: RSCDS XLV 9 · Crib: MiniCribbs · Diagram: Keith Rose's Diagrams

- 1-8 All circle 8H round & back
- 9-16 1s+3s dance the Swirl: Turn partner RH into Allemande hold & dance LSh round other couple 1/2 way, dance LH across & swirl to face side couples (BtoB with ptr & Lady facing Man)
- 17-24 All dance reels of 4 across
- 25-32 All set & dancing couples dance out between side couples, cross & cast to change places RH with partner back into places
- 33-40 All set & advance with partners, retire diagonally with corners & set
- 41-48 1L+4M dance R&L with 3L+2M (on diagonal)
- 49-56 1M+2L dance R&L with 3M+4L (other diagonal)
- 57-64 All set with corners, Adv+Ret with partners & set
- 65-88 2s & 4s repeat bars 9-32
- 89-96 All circle 8H round & back

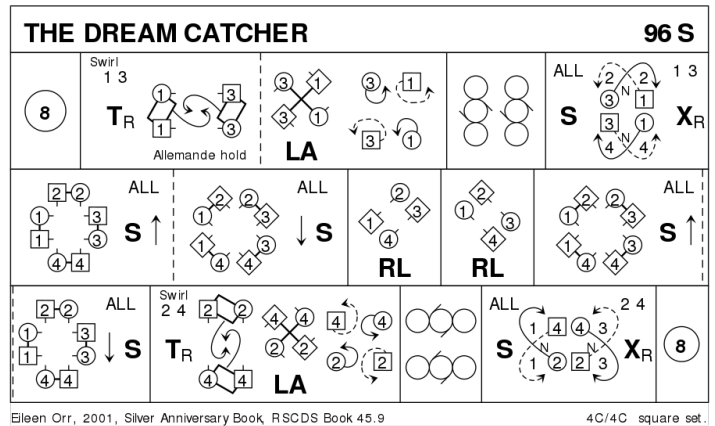

17 THE BEES OF MAGGIEKNOCKATER

J32 · 4/4L

John Drewry: *The Canadian Book of Scottish Country Dances* · Crib: *MiniCrib*s · Diagram: *Keith Rose's Diagrams*

- 1-8 1s cross RH & cast 1 place, dance RH across with 3s & end 1M+3L also 1L+3M in prom hold facing out to pass corner person RSh
- 9-24 All dance 4x1/2 Reels of 3 on sides (to right to start, then left, right & left) with 1s+3s changing partners in centre at end of each 1/2 Reel to progress Men clockwise & Ladies anticlockwise. End in centre 1s facing down & 3s facing up
- 25-32 1s dance between 3s turning 3s with nearer hand 1.1/2 times, crossing over to own sides & turn 4th person 1.1/2 times (Men RH & Ladies LH)

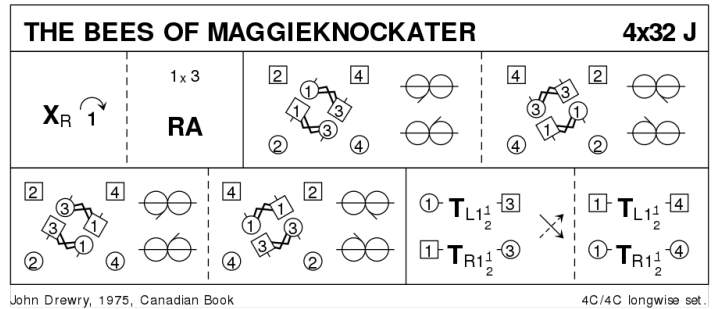

18 THE IRISH ROVER

R32 · 3/4L

James B Cosh: *Twenty Two SCD* · Crib: *MiniCrib*s · Diagram: *Keith Rose's Diagrams*

- 1-8 1s dance down below 3s & cast up to 2nd place own sides, 1L dances RH across with 2s while 1M dances RH across with 3s
- 9-16 1s dance 1/2 diagonal reel of 4 with 1st corners, 1/2 reel with 2nd corners & 1/2 turn LH in centre to face 1st corners
- 17-24 1s dance reels of 3 across giving LSh to 1st corners ending in 2nd place own sides
- 25-32 1s dance Diag R&L (1M crossing down & 1L crossing up to start)

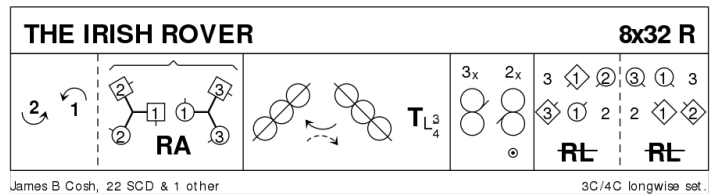

19 GOTHENBURG'S WELCOME

J32 · 3/4L

Bobby Munro: *RSCDS XXXVII 3* · Crib: *MiniCrib*s · Diagram: *Keith Rose's Diagrams*

- 1-4 1s cast 1 place & set advancing to 1st corner
- 5-16 1s Dance to Each Corner & Set:
 - 5- 6 1s change places with 1st corners passing RSh & 1st corners pass RSh with a 1/4 turn to right in centre to face 2nd corners (as 2nd corners set),
 - 7- 8 Original 1st cnrns change places with 2nd cnrns passing RSh & 2nd cnrns pass RSh with a 1/4 turn to right to face 1s in 3rd cnr (pstn) as 1s set
 - 9-10 Original 2nd corners change places with 1s passing RSh & 1s pass RSh with a 1/4 turn to right to face 2nd corner (pstn) as orig 1st corners set
 - 11-16 Repeat this Fig once more until 1s end in centre facing 3rd corner positions with 3s & 2s in 1st & 3rd places opposite sides
- 17-24 1s dance 1/2 diagonal Reel of 4 with 3rd corner, pass RSh & dance 1/2 diagonal Reel with 4th corners
- 25-32 1s dance RH hands across (L with 2s & M with 3s) & 2s+1s+3s turn RH

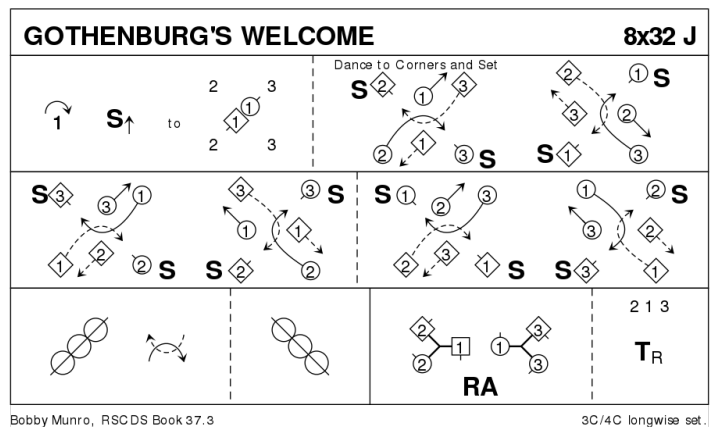

20 QUARRIES' JIG J32 · 3/4L

Kent W Smith: RSCDS XXXVI 3 · Crib: MiniCrib · Diagram: Keith Rose's Diagrams

- 1-8** 1s set, cast 1 place & dance round 1st corners passing corners LSh
- 9-16** 1s dance reels of 3 across (1st Man with 2s & 1st Lady with 3s), 1s turn LH to face 1st corners
- 17-18** Centre dancers change with 1st corners RH **while** 2nd corners set
- 19-20** 1st corners (in centre) change places LH **while** new 1st & 2nd corners dance clockwise round to next corner place
- 21-24** Repeat the Fig in bars 17-20 from new places
- 25-32** Repeat 17-20 from new places, 1s end by turning LH to 2nd place on opposite sides, 2s+1s+3s set on sides & 1s cross back RH

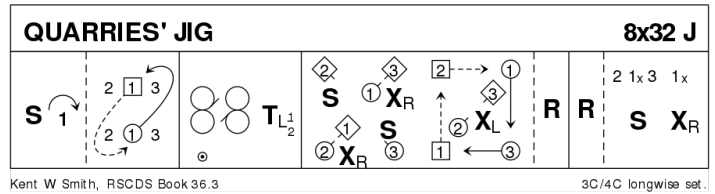

21 RAY MILBOURNE R32 · 4/4L

Derek Haynes: Carnforth Collection of SC Dances 1 · Crib: MiniCrib · Diagram: Keith Rose's Diagrams

2s & 4s start on opp sides

- 1-8** 1s & 4s cross RH, cast in 1 place & dance 1/2 Figs of 8 round end couples
- 9-16** 1s+4s dance 1/2 R&L, all dance 1/2 reels of 4 on sides
- 17-24** 3s+1s also 4s+2s dance Men's Chain
- 25-32** All circle 8H round & back

